



**GARDENESQUE**



**ROHAN WATER FEATURE**

**ANCIENT STONE**

# ROHAN WATER FEATURE

This user manual contains important information on how to set up and use Rohan ancient water feature. Read the user manual carefully, in particular the safety instructions, before using the product. Failure to follow this user manual may lead to severe injuries or product damage. This user manual is based on the standards and regulations that are required within GB.

## ROHAN ANCIENT STONE WATER FEATURE

---

|                   |                         |
|-------------------|-------------------------|
| MATERIAL          | Salt glazed ceramic     |
| PUMP              | Model - 1100LV          |
| POWER CONSUMPTION | 20w                     |
| FLOW RATE         | 1200 (l/h)              |
| OPERATING VOLTAGE | 120/220-240/12v 50/60HZ |
| PLUG              | (BS) 1363               |
| LED LIGHT         | YES, 1                  |

### COLOURS



Verdigris ancient stone

### DIMENSIONS

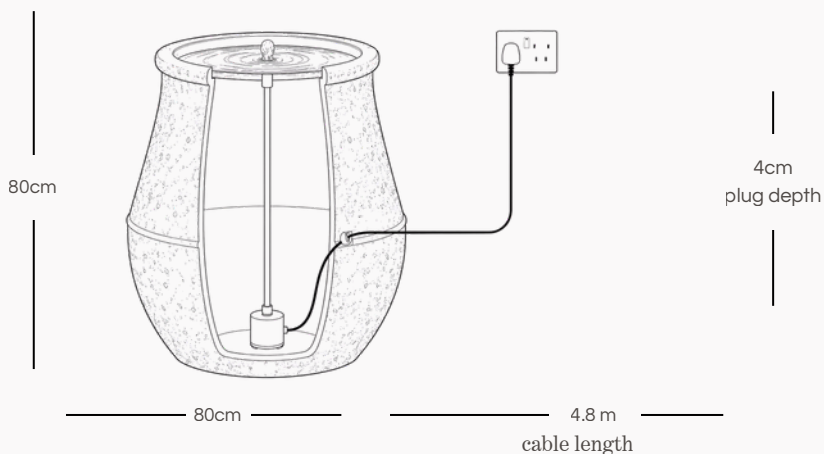

\*Due to the handmade nature of our ancient stone collection, sizes and finish may vary

## TECHNICAL INFORMATION

---

Elemental and grounded, the Ancient Collection embodies the distinct textures and historic longevity of natural stone through a unique salt glaze finish. With its timeless weathered look and traditional design, our Ancient pieces complement both rustic and contemporary garden spaces. Natural tones and materials blend seamlessly with minimalist greenery or more decorative blooms, making it easy to furnish your outdoor area no matter its style.

## PARTS

---

Unpack carefully onto a clear, smooth surface. Check that you have all the parts listed below. Refer to the assembly instruction overleaf before beginning to set up your fountain.



WATER  
FEATURE



PUMP



WATER  
PIPE

(Actual pump & pipe may differ from these images)

### ASSEMBLY

1



Connect the water pipe as illustrated below.

2



Connect the water pipe to the pump and place it into the water reservoir.

3



Fill with water, ensuring the pump is submerged. Distilled water is recommended.

4



Connect the plug into your mains outlet and turn on. If installed correctly, water will start to flow.

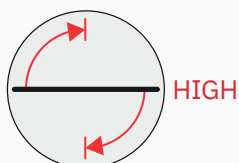

### PUMP FLOW RATE

The pump has a regulator that controls the rate of water flowing through the feature. This can be found at the water inlet, on the side of the pump. Operate as shown. It is recommended that the flow starts high, then is reduced if required.

## MAINTENANCE & CARE

---

### PERFORMANCE

A CLOGGED OR DIRTY INTAKE SCREEN WILL GREATLY REDUCE PERFORMANCE.

If the pump is used on a dirty surface, raise it slightly to reduce the amount of debris contacting the intake. If slower flow is desired, adjust the flow control lever on the side of the pump or restrict the discharge flow.

DO NOT let the pump run when not submerged in water. Doing so may damage the pump. Always submerge the pump in the water before plugging in the electrical outlet. It is common for air to be in the pump and tube when first plugged in. Continue to unplug the electrical cord and then plug it back in until water begins to flow. This pump is only to be used in an outlet with a ground fault interrupter (GFCI) or residual current device (RCD) with a rated residual operating current not exceeding 30 mA. Note: Ensure that the electrical cord loops below the electrical outlet to form a 'Drip loop'. This will prevent water from running down the cord into the electrical outlet.

### MAINTENANCE

Note: Always disconnect from the electrical outlet before handling the pump.

To clean the pump, remove the back cover and impeller. Use a small brush or steam water to remove debris.

### CLEANING

To maintain your water feature it should be cleaned periodically to avoid a build-up of algae or lime scale. However, before doing so the feature should be drained of water and the power turned off.

The water can be emptied from small, lightweight fountains by inverting them and letting the water pour away. Take care when doing this if your water feature is made up of more than one piece and be sure you can safely lift the weight of the feature.

For larger, heavier features, remove the water with a large sponge or by purchasing a simple syphon pipe from an aquatic supply store

### WINTER CARE

During the winter we suggest draining and covering the fountain, or storing it inside a shed, garage or outbuilding. Freezing water in a fountain can cause irreparable damage. Please note the damage caused by exposure to winter weather is not covered by any given warranty.

### PUMP

Please make sure that the pump is fully submerged in water. Regular topping up may be required in warm spells.

If the pump is working but water is not pumping, you may have a blockage. If this is the case, please check your pipe and pump inlet. If there is no sign of blockage, then check the fuse of the plug.

### FINISH & PAINTWORK

Lime scale will affect the appearance of your water feature. Clean regularly to avoid build up. The use of distilled water is recommended to minimise lime scale build up.

Paint or glaze may damage if left outside in the frost. Protect and empty the water from your fountain in cold weather to avoid this.

Parts are vulnerable to breaking off in extreme weather. Protect your fountain during high winds to avoid this.

## GENERAL INFORMATION

---

Keep this user manual for future reference. If you pass this product on to a third party, you must also supply this user manual.

The product is exclusively designed for outdoor use only. It is for private use only and not for commercial use.

Only use the product as described in this user manual. Any other use is improper and may lead to product damage or even personal injury.

This product is not a toy. The manufacturer or retailer assume no liability for damage caused by improper or incorrect use. Carefully remove the packaging before use but keep the safety instruments. These are part of the product. Please note all safety warnings mentioned in this manual. Read the instructions in their entirety and keep them for future reference. These must be stored with the product. This product is for household use and may not be used for commercial or contractual purposes.

For your safety - General safety instructions

- To operate this device safely, the user must have read and understood these instructions for use before using the device for the first time.
- Observe all safety instructions! Failure to do so may cause harm to you and others.
- Retain all instructions for use, and safety instructions for future reference.
- If you sell or pass the device on, you must also hand over these operating instructions.
- The device must only be used when it functions properly. If the product or part of the product is defective, it must be taken out of operation and disposed of correctly.
- Always ensure that a device which has been switched off cannot be restarted unintentionally.
- Do not use devices with an on/off switch that does not function correctly.

### Explanation of symbols

The following symbols are used on the product or packaging .



**Declaration of conformity** Products marked with this symbol meet all the applicable regulations of Great Britain.



### Declaration of conformity

Products marked with this symbol meet all the applicable Community regulations of the European Economic Area.



### RoHS Compliant.

RoHS is a product level compliance based on the European Union's Directive 2002/95/EC, the Restriction of the Use of certain Hazardous Substances in Electrical and Electronic Equipment (ROHS). ROHS Compliant'

## WARNING

---

### Electrical Safety

- The pump may only be connected to a socket that is correctly installed and grounded.
- Make sure that the power supply corresponds with the connection specifications of the device before it is connected.
- The pump may only be used within the specified limitations for voltage and power (see type plate).
- Do not touch the mains plug with wet hands! Always pull out the mains plug at the plug and not by the cable.
- Do not bend, crush, pull or drive over the power cable, protect from sharp edges, oil and heat.
- Do not lift the pump using the cable or use the cable for purposes other than intended.
- Check the plug and cable before each use.
- If the power cable is damaged immediately disconnect the plug. Never use the device if the power cable is damaged.
- If the water feature is not in use make sure the plug is pulled out.
- Make sure that the pump is switched off before plugging in the mains cable.
- Make sure that the pump is switched off before unplugging it.
- Disconnect the power supply before transporting the device

### FOR YOUR SAFETY - GENERAL SAFETY INSTRUCTIONS

- This appliance can be used by children aged from 8 years and above and persons with reduced physical, sensory or mental capabilities or lack of experience and knowledge if they have been given supervision or instruction concerning the use of the appliance in a safe way and understands the hazard involved. Children shall not play with the appliance. Cleaning and user maintenance shall not be made by children without supervision.
- Children of less than 3 years should be kept away unless continuously supervised.
- Children aged from 3 years and less than 8 years shall only switch on/off the appliance provided that it has been placed or installed in its intended normal operating position, and they have been given supervision or instruction concerning use of the appliance in a safe way and understand the hazards involved.
- Children aged from 3 years and less than 8 years shall not plug in, regulate and clean the appliance or perform user maintenance.
- If the supply cord is damaged, it must be replaced by the manufacturer, its service agent or similarly qualified persons in order to avoid a hazard.

## DEVICE SPECIFIC SAFETY INSTRUCTIONS

---

- The unit may not be operated indoors.
- The unit may not be operated in the vicinity of swimming pools, garden ponds etc.
- Do not move the unit when it is in use.
- Do not tilt the unit when it is in use.
- Always disconnect from electrical outlet before handling the pump.
- Never expose the plug to water.
- Symbols affixed to your pump may not be removed or covered. Information on the unit that is no longer legible must be re-placed immediately. Periodically change the water is recommended.
- Always ensure pump is fully submerged in water prior to use.
- Ensure the electrical cord loops below the electrical outlet to form a 'Drip loop'. This will prevent water from running down the cord into the electrical outlet.
- Risk of electric shock – this pump is supplied with a grounding conductor and grounding-type attachment plug. To reduce the risk of electric shock, be certain that this is connected only to the proper grounding -type receptacle.
- Do not remove the grounding pin from the plug.
- Do not connect to any voltage other than shown on the pump.
- The National Electric Code requires that a ground fault interrupter (GFCI) be used in the branch circuit supplying fountain pumps and other pond equipment. See your electrical supplies dealer for this device.
- To reduce the risk of electrical shock, use only on portable self-contained fountains no larger than 5 feet in any dimension.
- If fountain is not in use for a long period of time, unplug transformer, pour the water away, take out the pump out, and make sure the tank is dry.
- Operate pump completely submerged for proper cooling.
- Do not replace LED's except with suitable identical replacements approved by manufacturer.
- Only use the transformer provided.
- Avoid exposing product to subzero temperatures. Remove all water from product and keep in storage to avoid frost damage.
- Do not lift the pump by its power cord.
- Do not pump heated liquids.
- Operate by freshwater only. Don't use heavy chlorinated water and water with high PH levels. This pump has been evaluated for use with water only.
- This product is NOT allowed to be operated above 95 (35) or damage may occur.
- Do not pump flammable liquids.
- The pump is to be supplied through a residual current device (RCD) with a rated residual operating current not exceeding 30mA.
- Keep the cord away from high temperature and heat sources.
- Not for swimming pool or ponds.

## TROUBLESHOOTING

---

IF PUMP FAILS TO OPERATE, CHECK THE FOLLOWING.

A CLOGGED OR DIRTY INTAKE SCREEN WILL GREATLY REDUCE PERFORMANCE.

- Ensure that the pump's flow control switch is set to maximum (+) before operating. Once the flow is established, the pump can be adjusted downward to the desired level.
- If the pump operates, but there is no flow, check to ensure the pump is fully submerged.
- If the pump operates, but there is no flow, check the supply tubing for kinks and correct.
- Check the circuit breaker and try another outlet to ensure the pump is getting electrical power.
- Check the pump discharge and tubing for kinks and obstructions. Algae build up can be flushed out with a garden hose.
- Check the inlet to ensure it is not clogged with debris.
- If the pump operates, but there is no flow, and if the pump is submerged and there are no kinks in the supply tubing, lift the pump from the water. Remove supply tubing at pump outlet and clean tubing inside and out if necessary. Reset pump in water (outlet side up) and once water begins to flow, re-attach the supply tubing.
- Remove the pump inlet to access the impeller area. Turn the rotor to ensure it is not broken or damaged.
- Monthly maintenance will add to your pump's life.

### Loss of water

- Your fountain may be overfilled. Remove water if necessary.
- Make sure the correct flow setting is selected if your pump offers this function. Reduce the flow rate if necessary.
- Make sure your water feature is completely level. If your water feature is on a slope, this can disturb the pumping process.
- Evaporation, weather and wildlife can affect the water level. Regular topping up may be required, particularly in warm spells.

## WARRANTY

---

THE WATER FEATURE OR PART IS NOT COVERED UNDER THE WARRANTY IN THESE FOLLOWING CASES:

- If the pump has a visible algae or limescale build up.
- Signs of electrical residue / burning odour.
- Blistering / swelling on the casing of the pump.
- Discolouring that has the appearance of rust.
- Damage to the plug or moulded inserts.
- The transformer has a visible build-up of dirt and/or debris.
- Surface damage / discolouration due to limescale.
- Products damaged by misuse or severe weather conditions.
- Products that have formed cracks not reported within 28 days from purchase.
- Products that have formed leaks not reported within 28 days from purchase.
- Do not dispose of any of the components in case further inspection is required.

### Disposal of the appliance



Appliances which are labelled with the above symbol must not be disposed of in household waste. You must dispose of such old electrical and electronic equipment separately. Through separate disposal you send old equipment for recycling or for other forms of re-use. You will thus help to avoid in some cases that damaging material gets into the environment. For private households: Information on Disposal for Users of WEEE this symbol on the products) and / or accompanying documents means that used electrical and electronic equipment (WEEE) should not be mixed with general household waste. For proper treatment, recovery and recycling, please take this products) to designated collection points where it will be accepted free of charge. Disposing of this product correctly will help save valuable resources and prevent any potential negative effects on human health and the environment, which could otherwise arise from inappropriate waste handling. Please contact your local authority for further details of your nearest designated collection point. Penalties may be applicable for incorrect disposal of this waste, in accordance with your national legislation. For disposal in countries outside of the European Union This symbol is only valid in the European Union (EU). If you wish to discard this product please contact your local authorities or dealer and ask for the correct method of disposal. Disposal of the packaging